

CAD FILE:

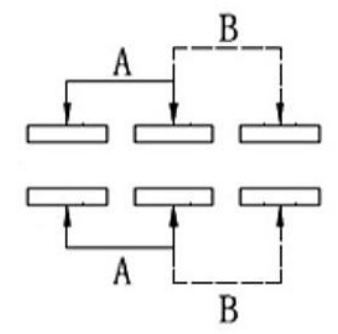

Circuit Diagram

PCB Layout(Pattern side)

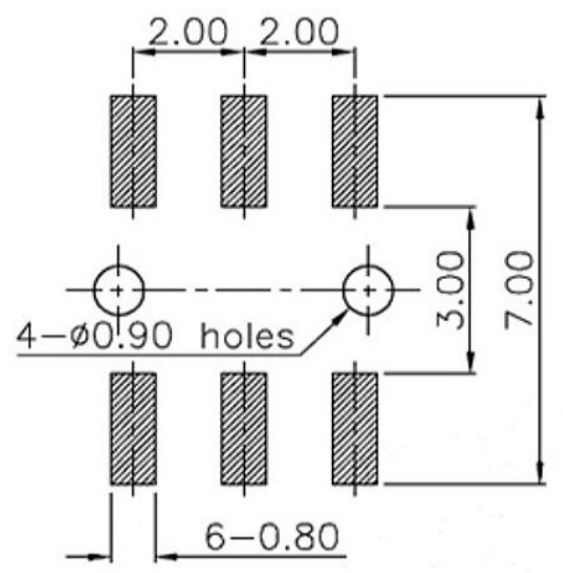
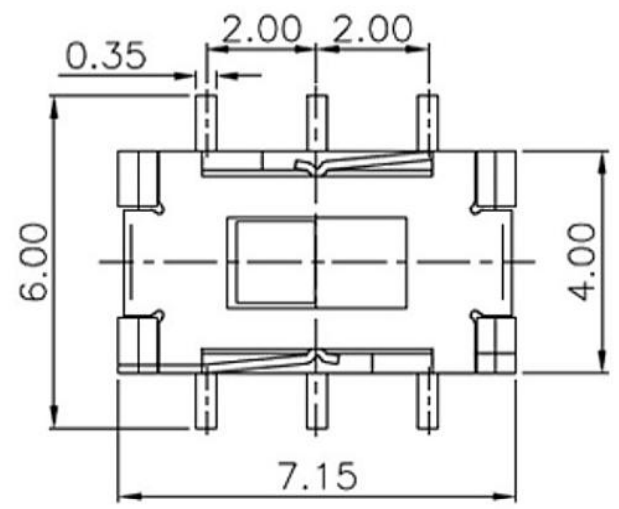
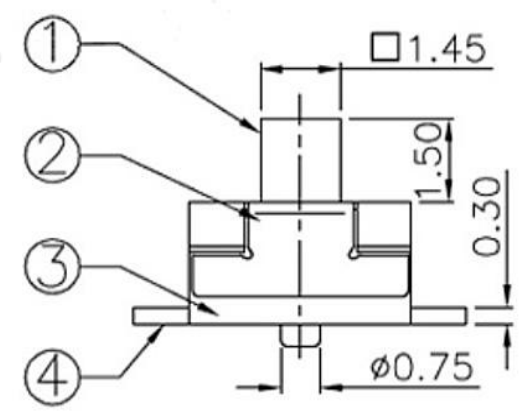
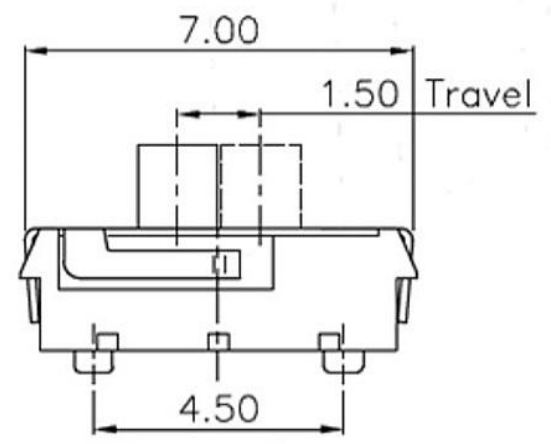

注：“*”表示关键尺寸(6个)

NO.	PARTS	MATERIALS	Q'TY	FINISH	TOLERANCE		UNLESS SPECIFIED		DESCRIPTIONS OF REVISION		APPD.	
8												
7	STEEL BALL	STEEL	1	NATURAL								
6	SPRING	STEEL WIRE	1	NATURAL								
5	CONTACT CLIP	PBS STRIP	2	Ag PLATED								
4	TERMINAL	BRASS STRIP	8	Ag PLATED								
3	BASE	PHENOLIC RESIN	1	NATURAL								
2	FRAME	STEEL STRIP	1	Ni PLATED								
1	KNOB	POM	1	BLACK								
					TITLE : SLIDE SWITCH			UNIT : mm	DRWG NO.:			
					MODEL:			SCALE: 3:1	DWN.	2012-10-26		
					東莞市高迪電子有限公司 DONGGUAN GAODI ELECTRONICS CO., LTD.			ISSUE		DATE	2012-10-26	初版
								APPD.			2012-10-26	